

VEROFLEX

The preferred high flexibility RF Cable

Features

- High Flexible
- Low Insertion Loss

Typical Applications

- RF Module
- Anechoic Test Chambers
- Automated Test Equipment
- Wireless Telecommunication Module Testing



Cable Structure

VF18

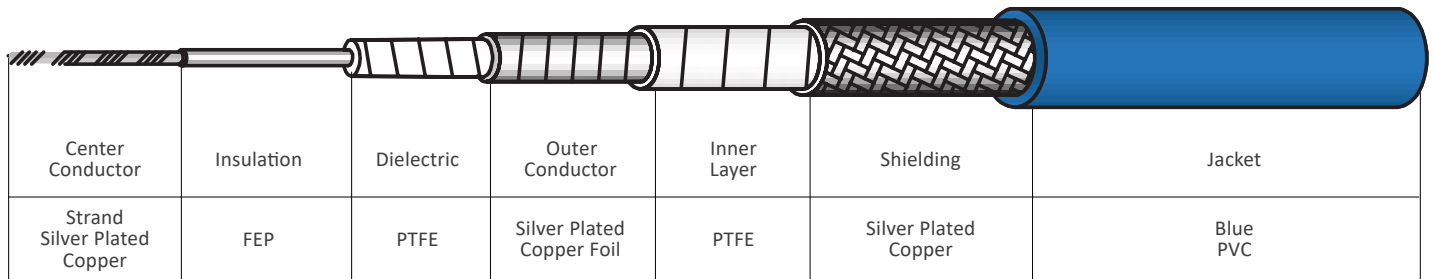

VF18-armor

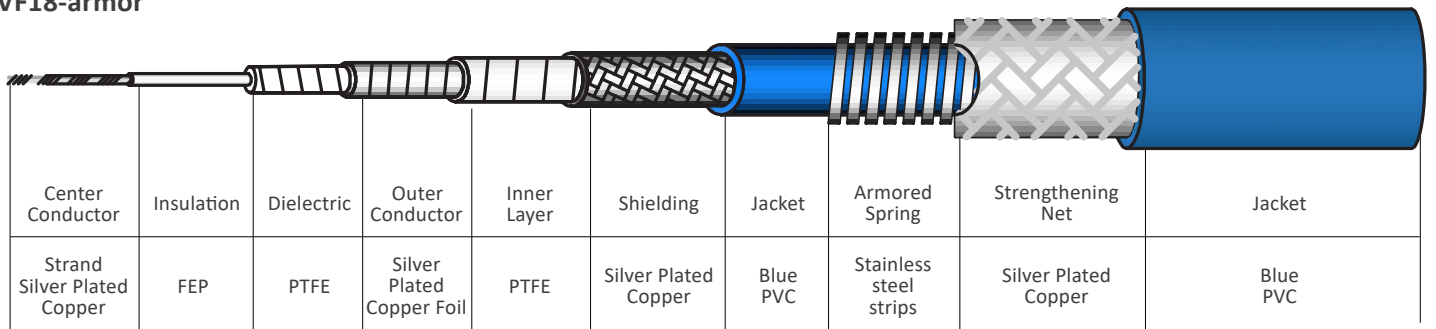

VF26

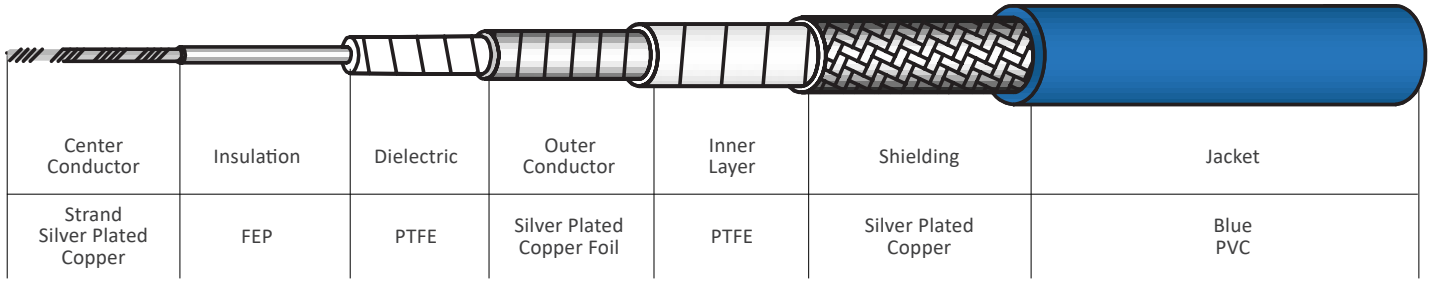

VF26-armor

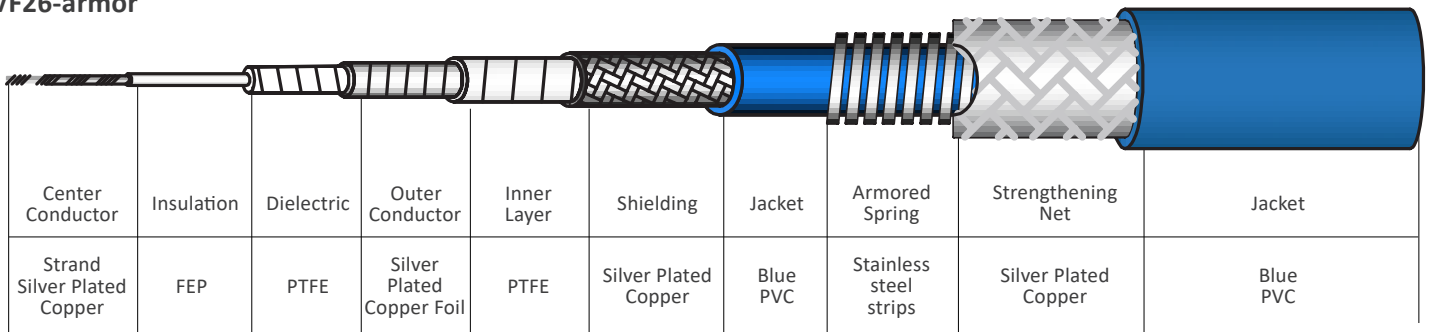

VF40 & VF50

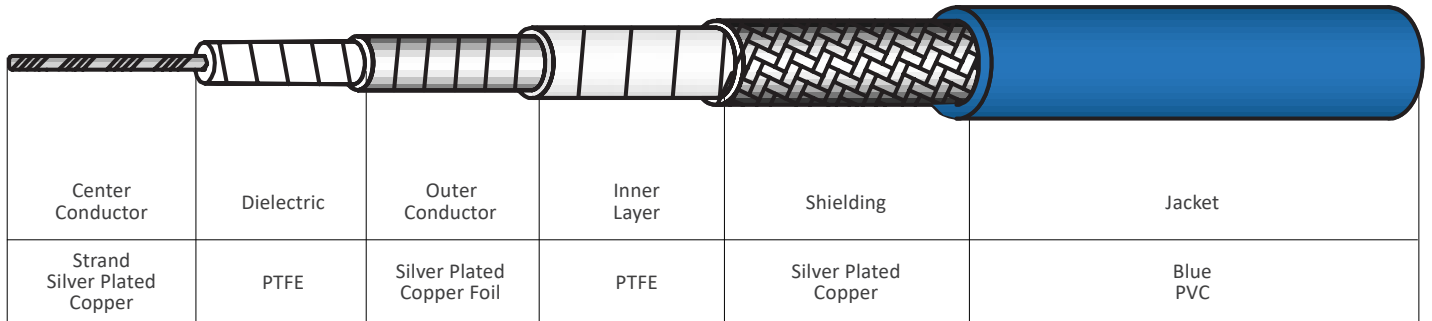

VF40-armor & 50-armor

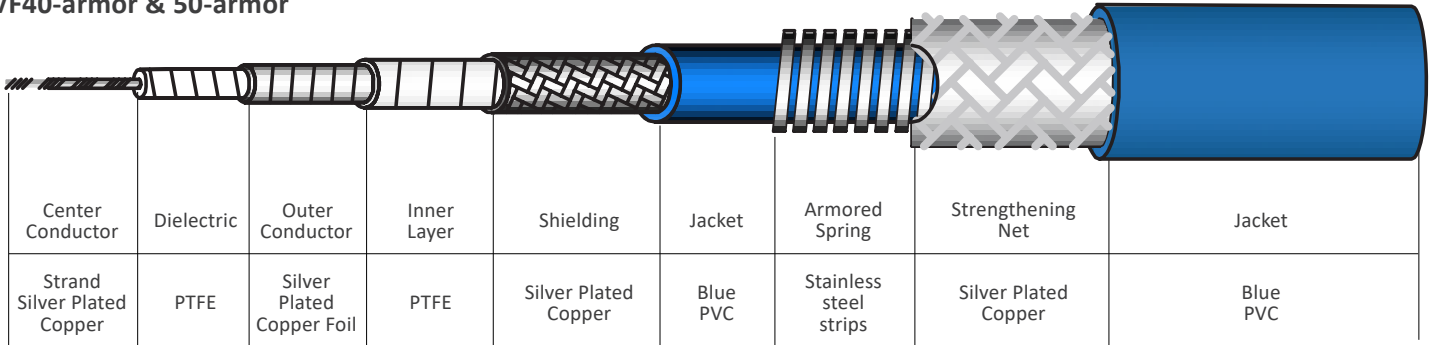

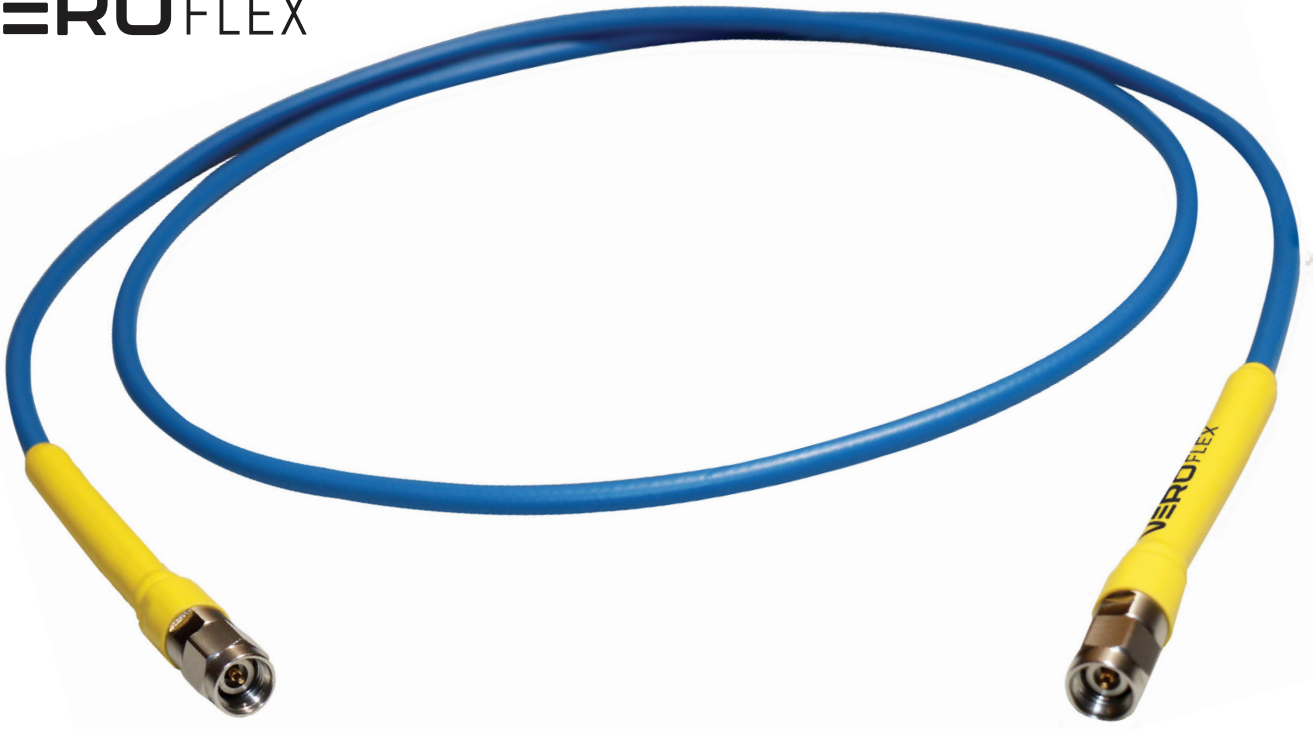

Specifications

Cable	VF18	VF18-armor	VF26	VF26-armor	VF40	VF40-armor	VF50	VF50-armor
Center Conductor	Stranded		Stranded		Stranded		Stranded	
Overall Diameter (mm)	5.5	9.0	6.0	9.0	4.3	6.0	4.0	6.0
Nominal Weight (g/m)	60	174	65	177	40	105	38	107
Minimum Bend Radius (mm)	28	40	30	40	22	25	20	25
Max Flex Cycles	200,000		200,000		200,000		200,000	
Temperature Range (°C)	-40/85		-40/85		-40/85		-40/85	
Maximum Frequency (GHz)	18.0		26.5		40		50	
Typical VSWR	1.19:1		1.22:1		1.25:1		1.25:1	
Maximum VSWR	1.3		1.30:1		1.35:1		1.40:1	
Max. Insertion Loss (dB/m)	1.98		1.6		3.07		4.9	
Impedance (Nominal) (Ohms)	50		50		50		50	
Phase Stability vs. Flexure	±5.0		±6.0		±6.0		±8.0	
Amplitude Stability vs. Bending(dB)	< ±0.1		< ±0.1		< ±0.15		< ±0.15	
Amplitude Stability vs. Shaking(dB)	< ±0.1		< ±0.1		< ±0.15		< ±0.15	
Dielectric Constant (Nominal)	1.83		1.45		1.52		1.83	
Velocity of Propagation (Nominal) (%)	74		83		81		74	
Time Delay (Nominal)(ns/cm)	0.045		0.0401		0.041		0.045	

VF26 Attenuation

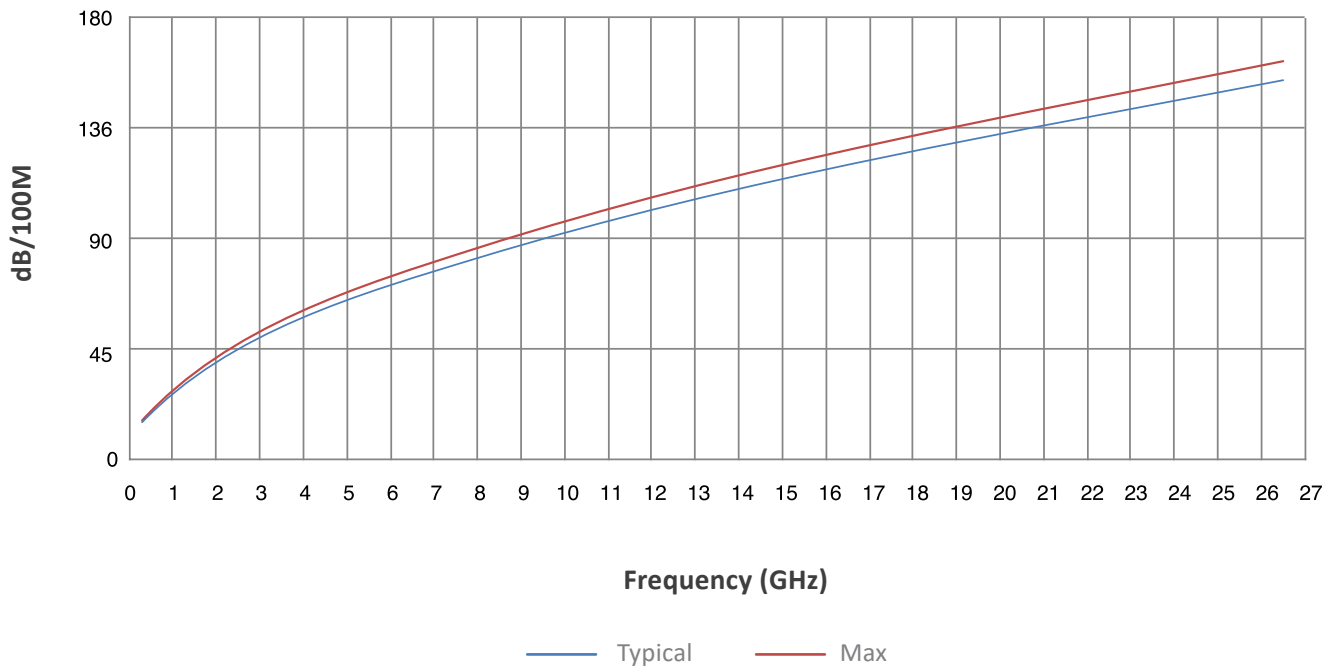

VF26 Average Power

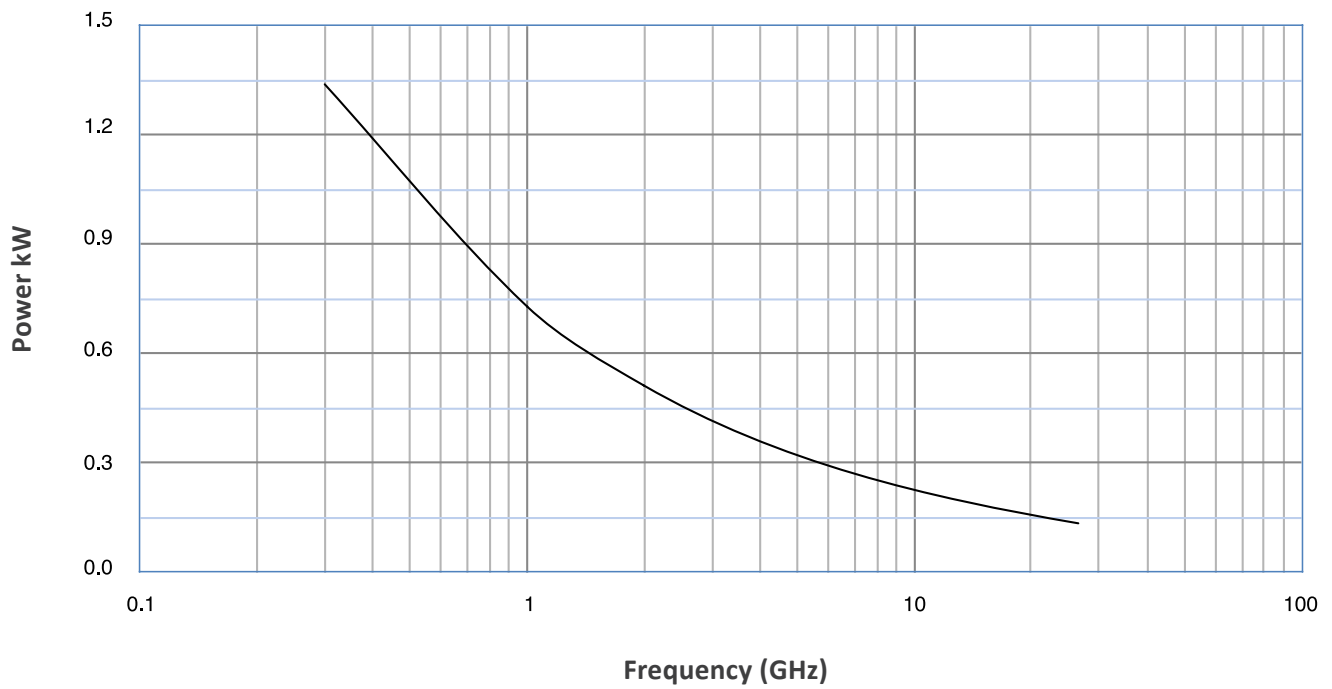

VF50 Attenuation

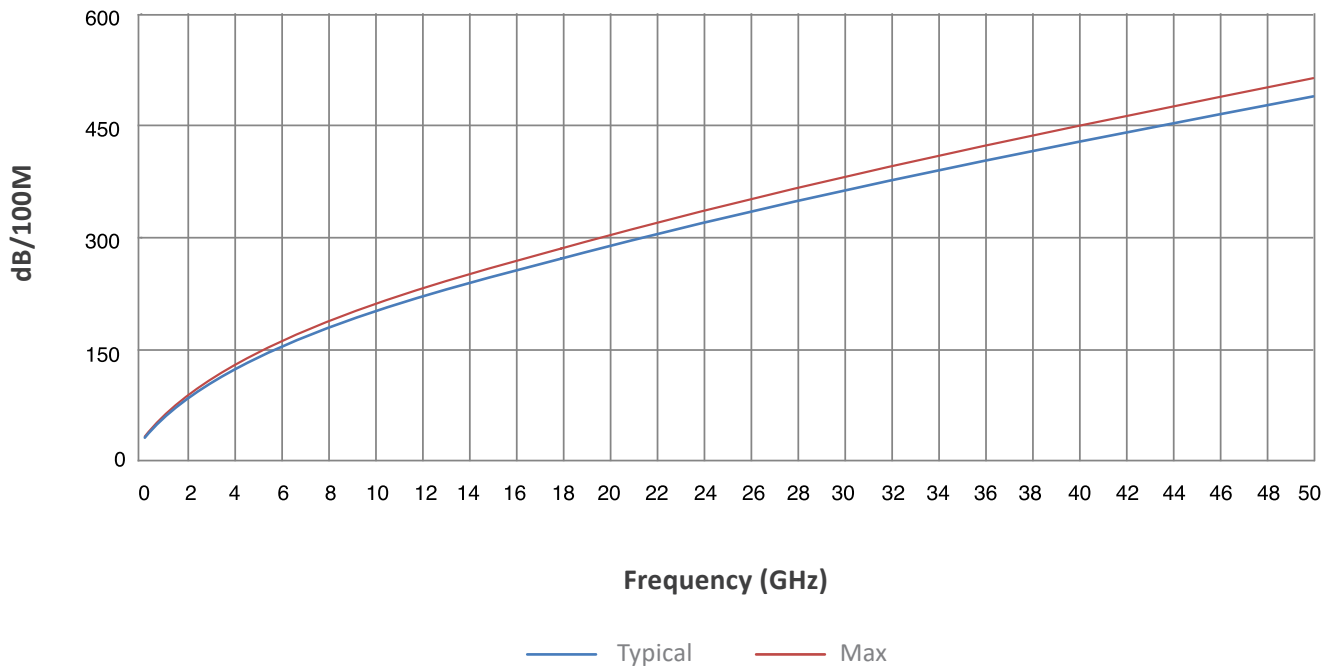

VF50 Average Power

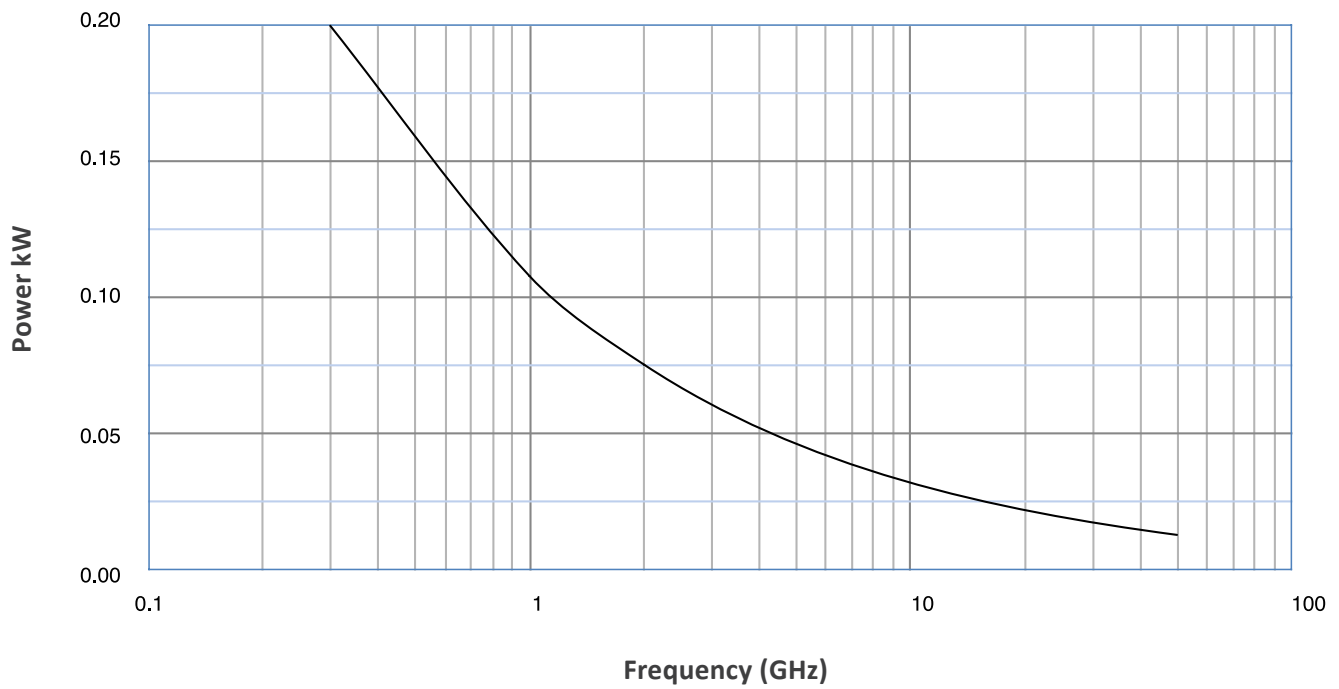

Selecting The Suitable Cable: Part Number Construction

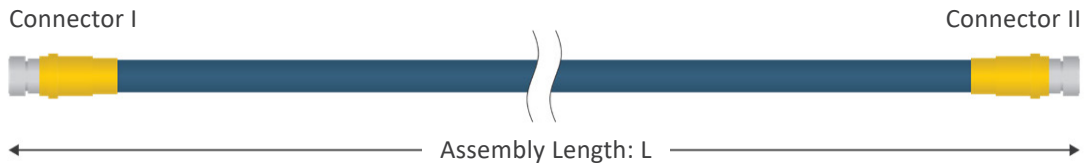

Cable Type-Length Conn (I)Conn (II) - A

VF18-01000 SMM SMM-N



1	Cable Type	Cable Code	2	Length Requirement	Length Code			
	VEROFlex Operating@Max 18GHz	VF18		1000mm	01000			
3	Connector (I)	Connector Code	4	Connector (II)	Connector Code	5	With Armor	No Armor
	SMA Male	SMM		SMA Male	SMM		A	N

Criteria for Connector Selection

Connector Type	Mate	Connector Code			Max Operating Frequency (GHZ)	VF18/ VF18-armor	VF26/ VF26-armor	VF40/ VF40-armor	VF50/ VF50-armor
SMA	M	S	M	M	26.5	●	●	●	
SMA RA	M	A	S	M	18.0	●			
SMA	F	S	M	F	18.0	●			
N Type	M	N	N	M	18.0	●	●		
TNC	M	T	N	M	18.0	●			
3.5mm	M	D	M	M	26.5		●		
2.92mm	M	K	M	M	40.0			●	●
2.92mm RA	M	R	K	M	40.0				●
2.92mm	F	K	M	F	40.0				●
2.4mm	M	L	M	M	50.0				●
2.4mm	F	L	M	F	50.0				●

Available Standard Connectors

VF18

Type SMA Male Code SMM

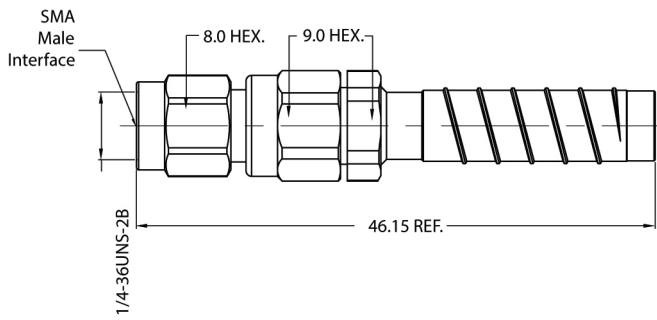

Type N Male Code NNM

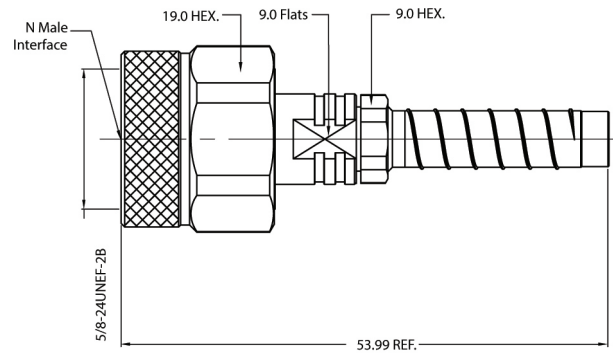

Type SMA Male RA Code ASM

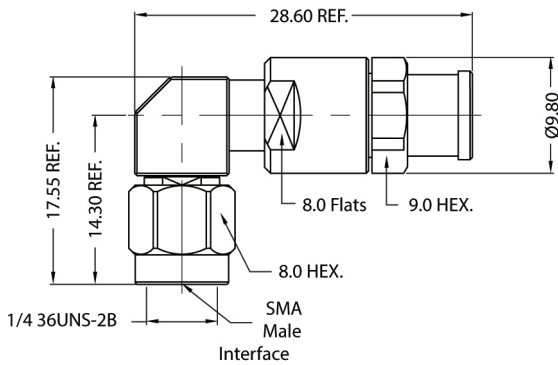

Type TNC Male Code TNM

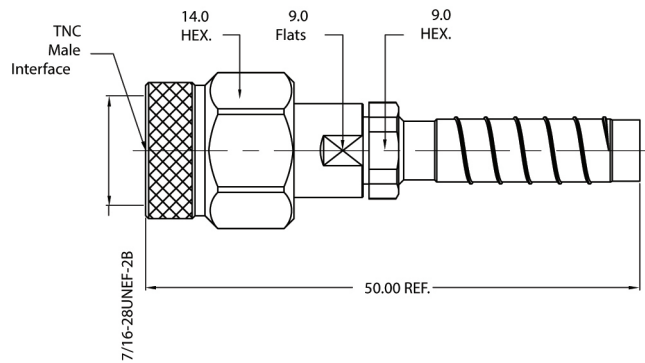

Type SMA Female Code SMF

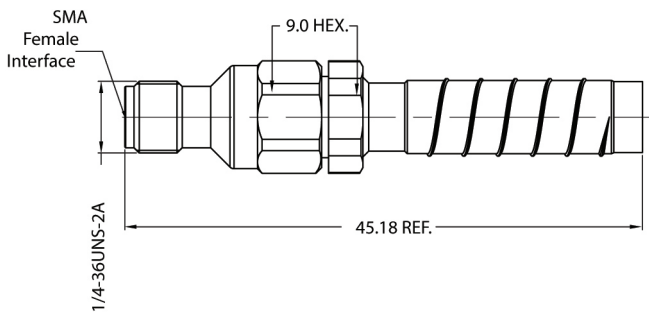

Available Standard Connectors

VF18-armor

Type SMA Male Code SMM

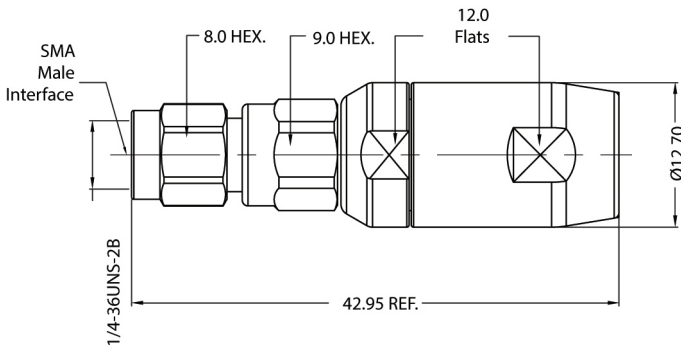

Type N Male Code NNM

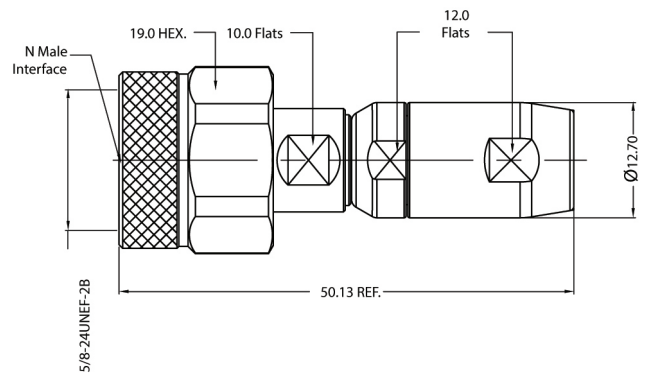

Type SMA Male RA Code ASM

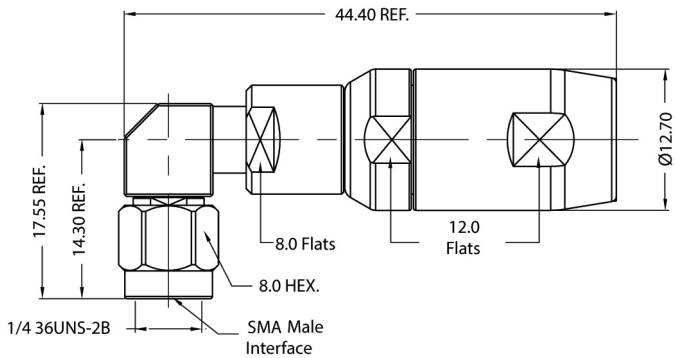

Type TNC Male Code TNM

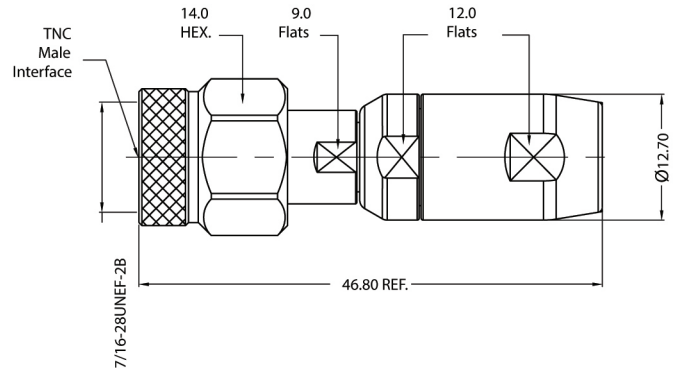

Type SMA Female Code SMF

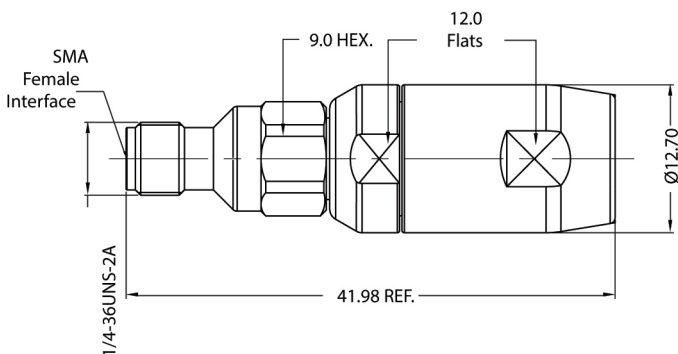

Available Standard Connectors

VF26

Type SMA Male Code SMM

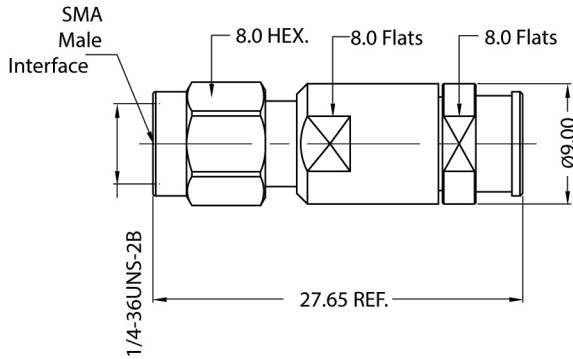

Type 3.5mm Male Code DMM

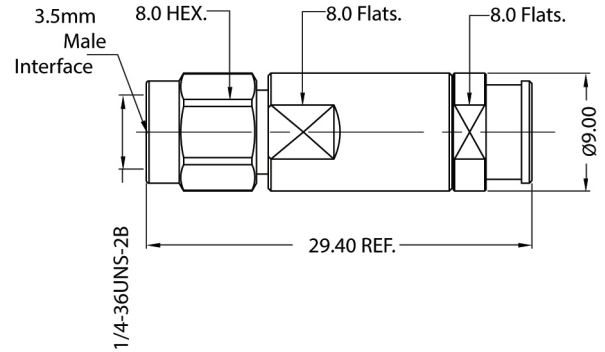

Type N Male Code NNM

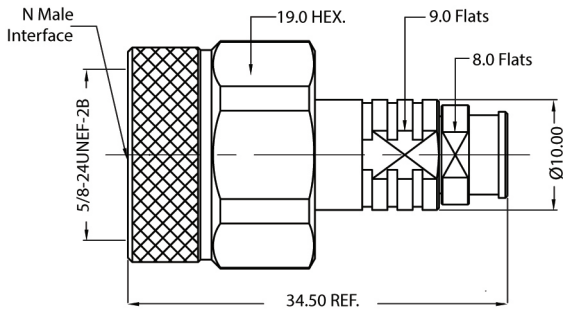

VF26-armor

Type SMA Male Code SMM

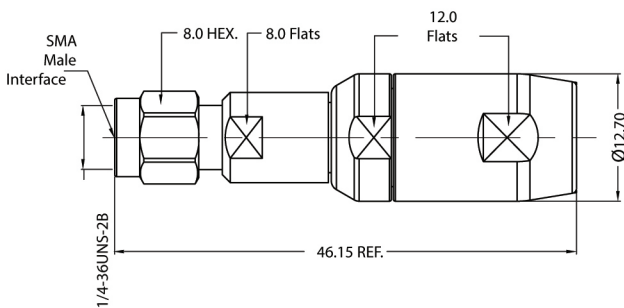

Type 3.5mm Male Code DNM

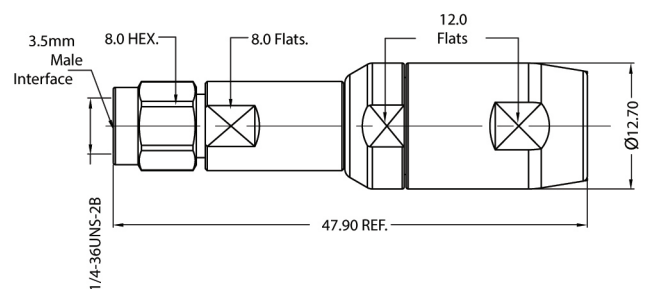

Type N Male Code NNM

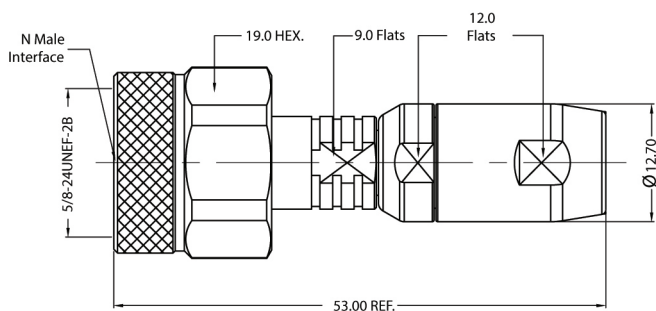

Available Standard Connectors

VF40

Type SMA Male Code SMM

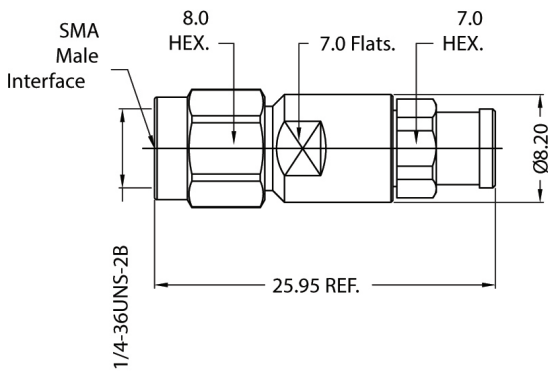

Type 2.92mm Male Code KMM

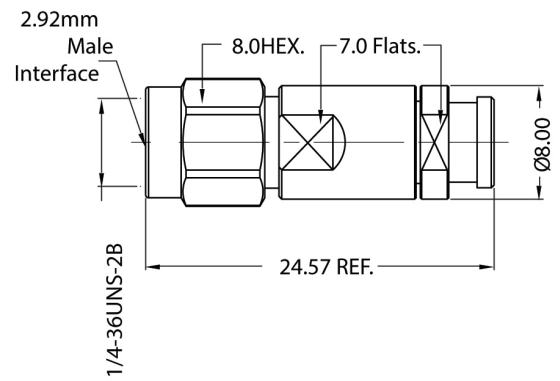

VF40-armor

Type SMA Male Code SMM

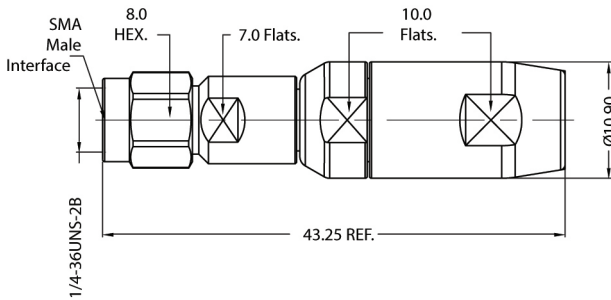

Type 2.92mm Male Code KMM

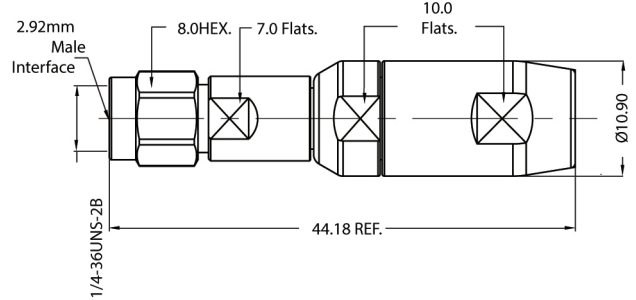

Available Standard Connectors

VF50

Type 2.92mm Male Code KMM

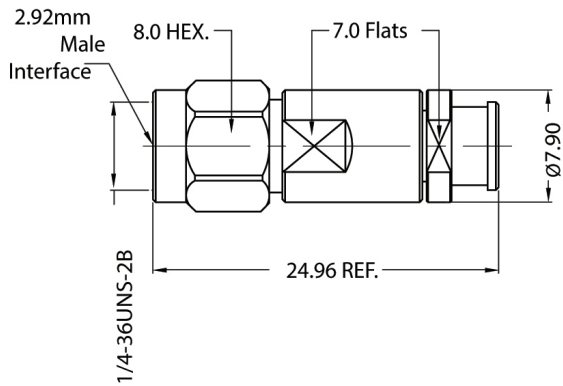

Type 2.4mm Male Code LMM

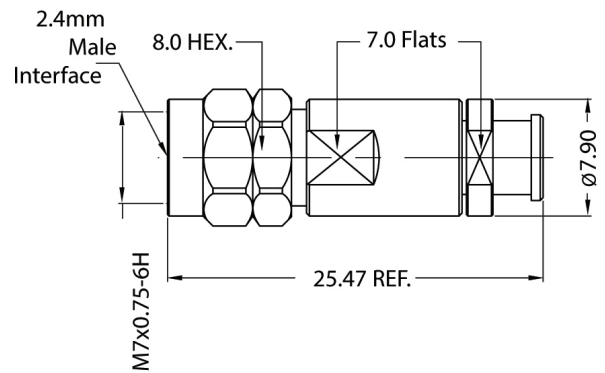

Type 2.92mm Male RA Code RKM

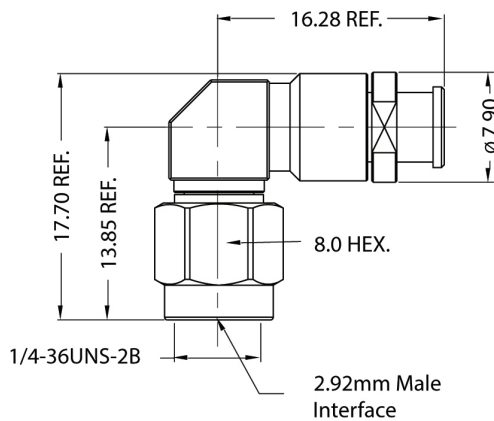

Type 2.4mm Female Code LMF

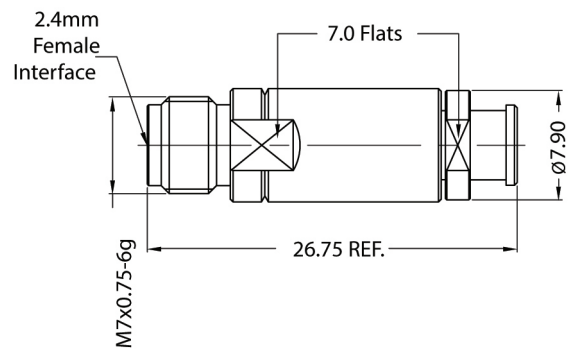

Type 2.92mm Female Code KMF

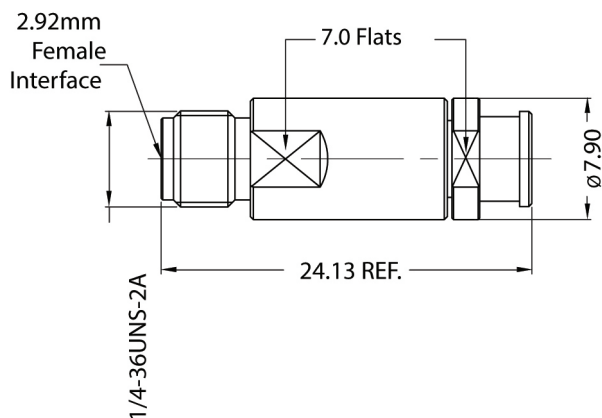

Available Standard Connectors

VF50-armor

Type 2.92mm Male Code KMM

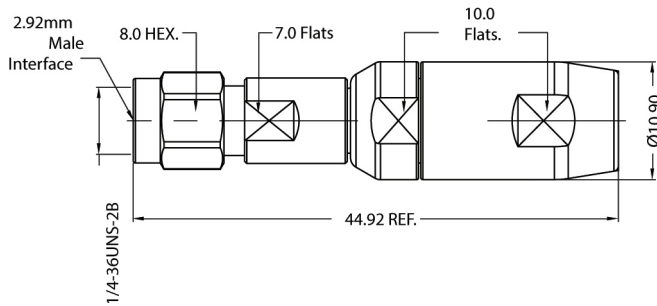

Type 2.4mm Male Code LMM

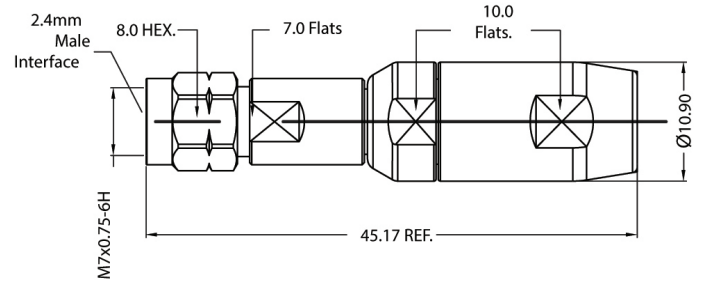

Type 2.92mm Male RA Code RKM

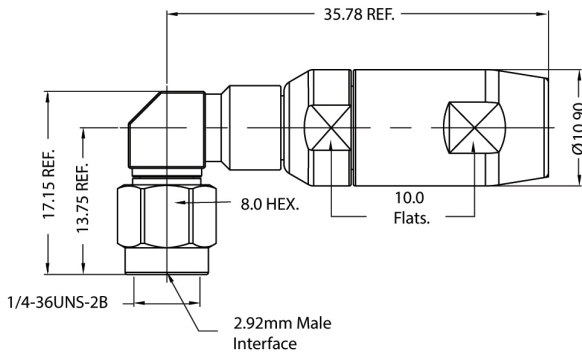

Type 2.4mm Female Code LMF

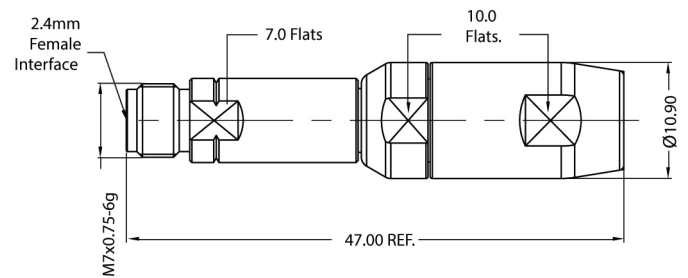

Type 2.92mm Female Code KMF

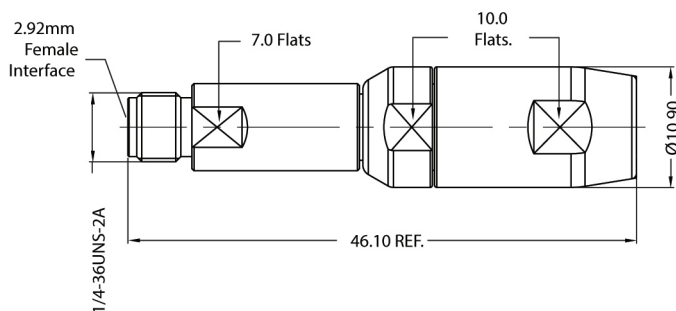

© 2024 Verotronic Technologies Pte Ltd. All rights reserved. All information contained in this document is provided in connection with the products and services of Verotronic Technologies Pte Ltd (Verotronic). While every effort has been made to ensure accuracy, Verotronic assumes no responsibility for errors, omissions, or decisions made reliant upon this information. Verotronic may change related products, specifications, product description and documentation at any time, without prior notice. Any brand and logo depicted remain the intellectual property of its owner.